

VACUUM CYLINDERS

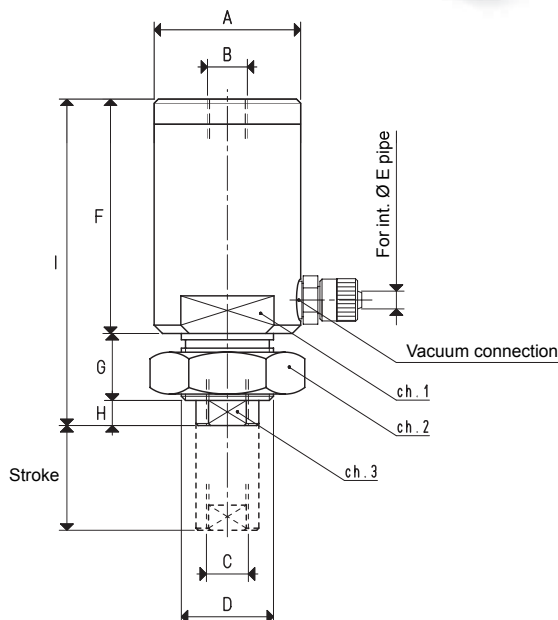

The cylinders described in this page are vacuum operated. By creating vacuum in the cylinder front chamber, the stem, which is solidly connected to the piston, comes out overcoming the opposing spring force.

The piston is pushed by the air at atmospheric pressure that gets into the cylinder's rear chamber through the hollow stem.

The greater the pressure differential between the front chamber under vacuum and the rear chamber at atmospheric pressure, and the larger the piston thrust force will be.

The stem returns into position in two ways:

- 1) By preventing the atmospheric air from entering through the stem hole and with the vacuum inserted, the pressure differential inside the cylinder is removed. Under this condition, the thrust spring and the atmospheric pressure forces prevail on the stem which is thus pushed into its initial position.
- 2) By excluding the vacuum, the atmospheric pressure is restored in both the cylinder chambers. Also in this case, being the pressure differential removed, the stem returns to its initial position pushed by the thrust spring.

The first of these two methods is the true operating principle for which this cylinder has been designed. In fact, by assembling a vacuum cup on the cylinder hollow stem and creating a vacuum, the cup will rapidly come into contact with the object to be handled and it will automatically lift it keeping the grip until the vacuum is excluded.

For this feature, vacuum cylinders associated with vacuum cups are recommended for gripping and handling machined, moulded or thermoformed objects, as well as for separating sheets of paper or plastic, sheet steel, etc. and lifting printed circuits or thin plastic panels.

The advantages offered by these vacuum cylinders include: brief and quick cycles controlled by only one valve for vacuum interception; automatic compensation of the height of the objects to be gripped with no compression on them; non-rotating piston and an extremely easy fixing. They are fully made with anodised aluminium and are equipped with a special self-lubricating technopolymer bush which guarantees long duration.

Art.		25 05 10	25 10 10	25 15 10
Stroke	mm	17	25	30
Thrusting force at -KPa 80	Kg	2.0	4.3	12.0
Lifting force at -KPa 80	Kg	0.45	1.0	2.5
Minimum cycle time	sec	0.3	0.4	0.6
Min. vacuum level	-KPa	60	60	60
Min. capacity necessary	Nl/1'	15	30	90
Working temperature	°C	5 ÷ 80	5 ÷ 80	5 ÷ 80
Weight	g	55	145	515
A	∅	24	35	59
B	∅	M 6	G1/8"	M 10
C	∅	M 5	G1/8"	G1/4"
D	∅	M 16 x 1.5	M 22 x 1.5	M 40 x 1.5
E	Pipe vacuum connection	∅ int.	4	4
F		39.5	56	66
G		12	16	17
H		4	6	9
I		55.5	78	92
Ch. 1		19	27	50
Ch. 2		24	32	55
Ch. 3		8	12	17

Note: By adding the letters PZ to the code, the cylinder will be supplied with technopolymer piston (E.g.: 25 05 10 PZ).

Conversion ratio: inch = $\frac{mm}{25.4}$; pounds = $\frac{g}{453.6} = \frac{Kg}{0.4536}$

GAS-NPT thread adapters available at page 1.117