

VANE MINI VACUUM PUMPS

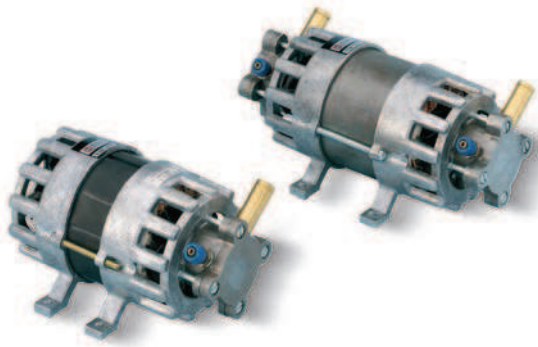

These rotating vane mini vacuum pumps, when needed, can be used even for compressing air. They are composed of a single-phase induction electric motor with condenser, a sintered metal self-lubricating stator, a white metal rotor fitted onto the motor shaft and slotted for housing the hardened steel vanes and a silencer on the exhaust. The operation principle is the same as that of the larger series of vane vacuum pumps. They are noiseless and lubrication-free and require no maintenance. Thanks to their minimal overall dimensions and their reduced weight, they are particularly suited for being installed on portable equipment. They are suitable for discontinuous, non-intense use.

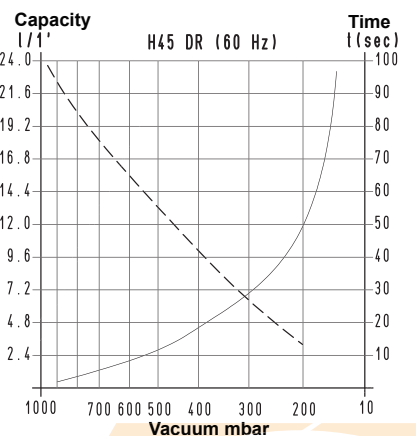
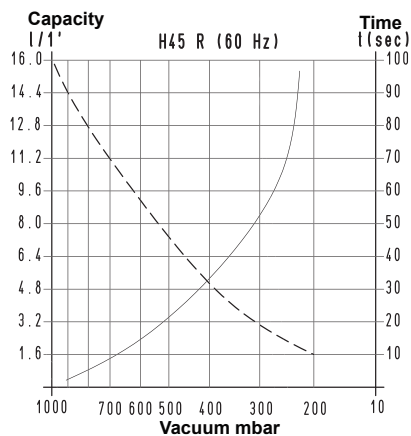
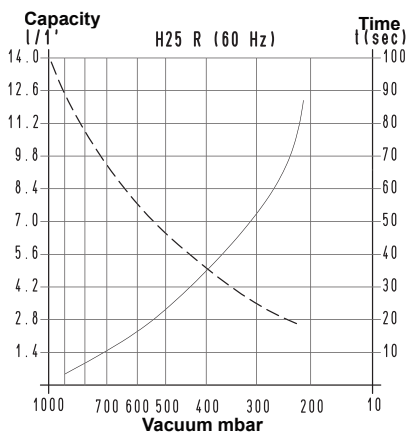
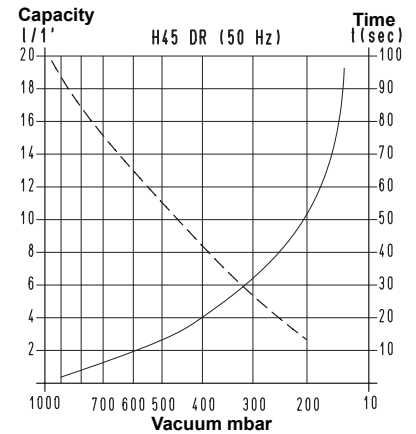
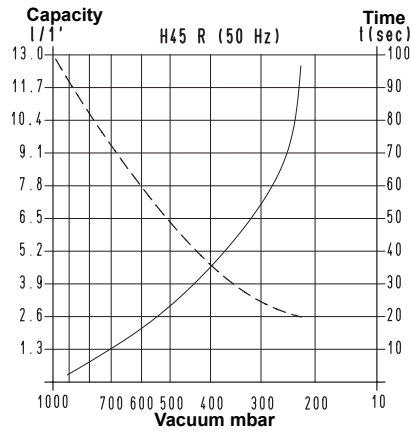
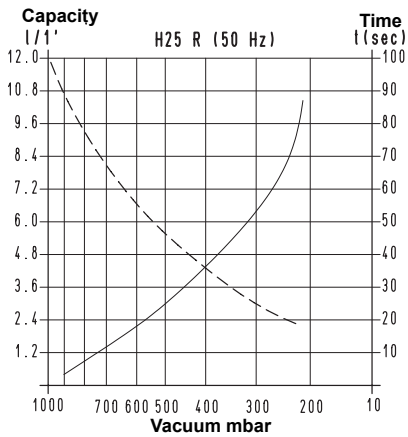

To calculate the emptying time of a volume V_1 , apply the formula $t_1 = \frac{t \times V_1}{6}$

- Curve regarding capacity (referring to a 1013 bar pressure)
- Curve regarding the emptying of a 6-litre volume

- V_1 : Volume to be emptied
- t_1 : Time to be calculated (sec)
- t : Time obtained in the table (sec)

VANE MINI VACUUM PUMPS

H 25 R

H 45 R

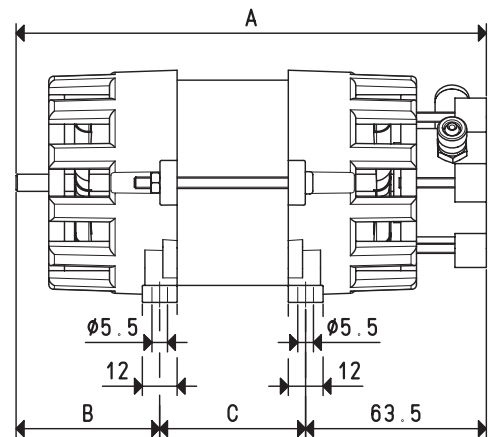
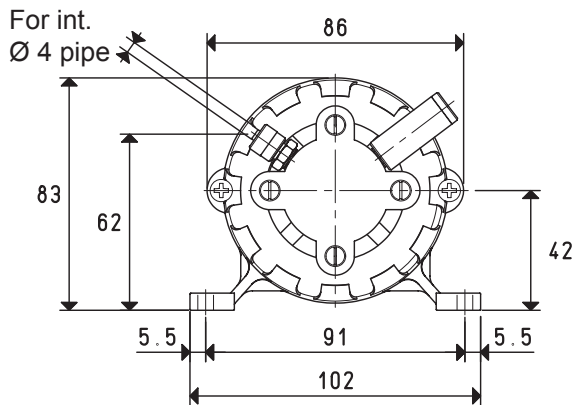

H 45 DR

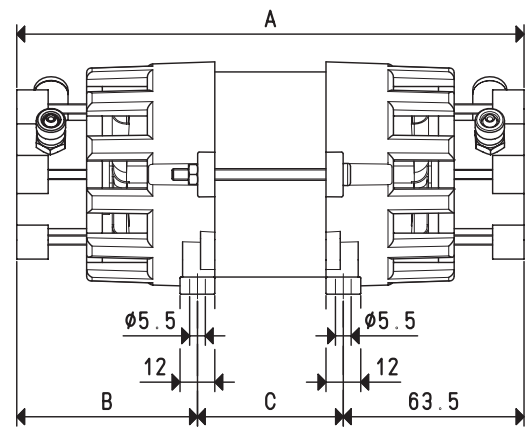
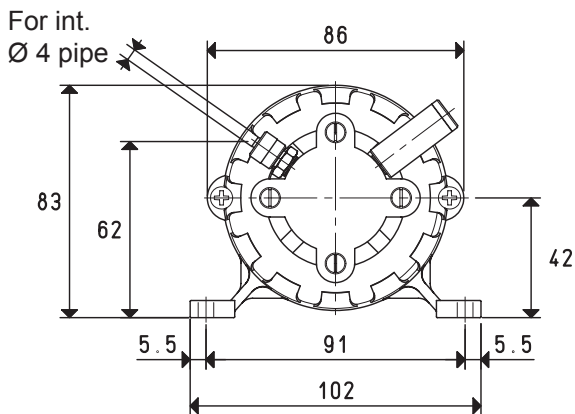

Art.	H25 R		H45 R		H45 DR	
Frequency	50Hz	60Hz	50Hz	60Hz	50Hz	60Hz
Nominal capacity:						
Connection in series	l / l'	11.5	13.8	13.0	15.5	11.0
Connection in parallel	l / l'	=	=	=	=	10 + 10
Final pressure:						
Connection in series	mbar abs.	150		200		40
Connection in parallel	mbar abs.	=		=		150
Max. pressure	bar (g)	2		2		2
Motor execution	1~	230 ± 10%		230 ± 10%		230 ± 10%
Volt						
Motor power	1~	28	33.5	35	42	40
Watt						
Condenser	µF	2.50		3.15		3.15
Electric absorption	A	1.2		1.5		1.8
Rotation speed	rev/min ⁻¹	2800	3300	2800	3300	2800
Noise level	dB(A)	≤ 60		≤ 60		≤ 60
Max. weight	Kg	1.45		2.0		2.1
A		148		165		180
B		45.5		47.5		63.5
C		38		53		53
Accessories and spare parts						
Vanes	art.	n° 10 00 H25R 03		n° 10 00 H45R 02		n° 20 00 H25R 03
Silencer filtre	art.	FB 1		FB 1		FB 1
Fittings	art.	RMM5		RMM5		RMM5

3D drawings available at www.vuototecnica.net

VANE MINI VACUUM PUMPS WITH DC MOTOR

The previously described mini pumps can be supplied with a DC motor instead of an AC one.
The performance is practically the same.

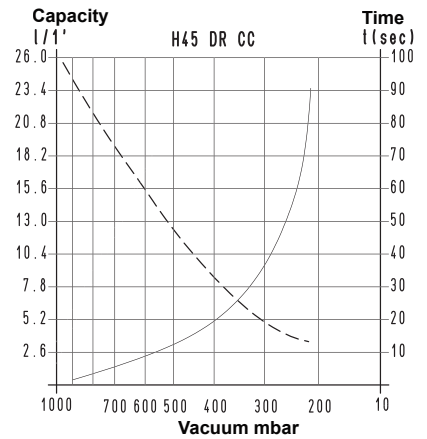
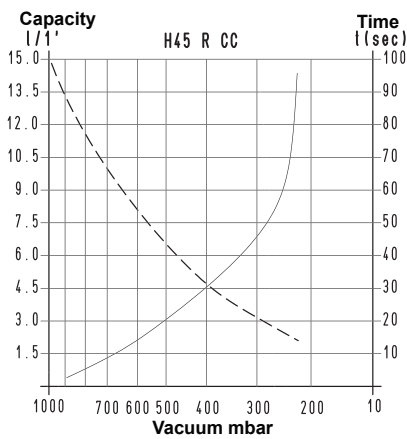
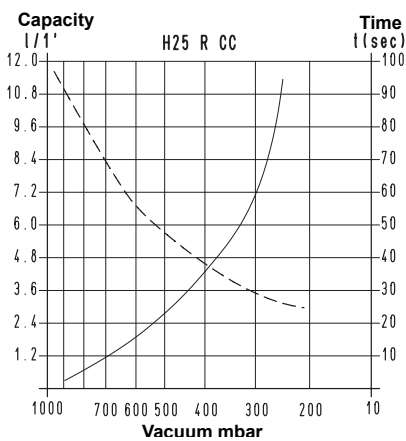
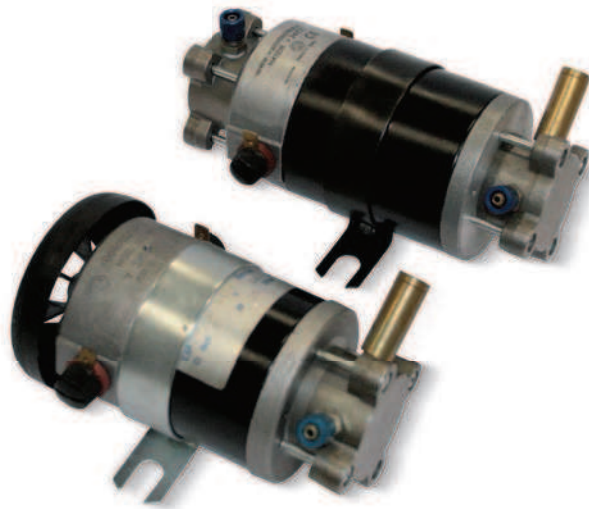

To calculate the emptying time of a volume V_1 , apply the formula $t_1 = \frac{t \times V_1}{6}$

- Curve regarding capacity (referring to a 1013 bar pressure)
- Curve regarding the emptying of a 6-litre volume

- V_1 : Volume to be emptied
- t_1 : Time to be calculated (sec)
- t : Time obtained in the table (sec)

VANE MINI VACUUM PUMPS WITH DC MOTOR

H 25 R CC

H 45 R CC

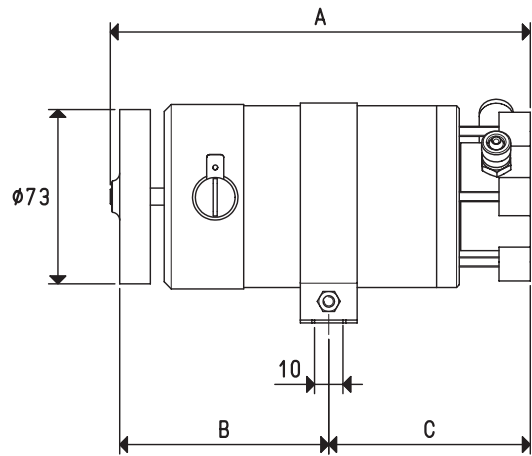
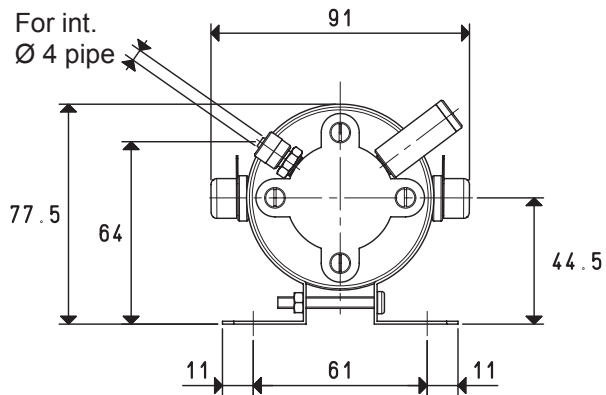

H 45 DR CC

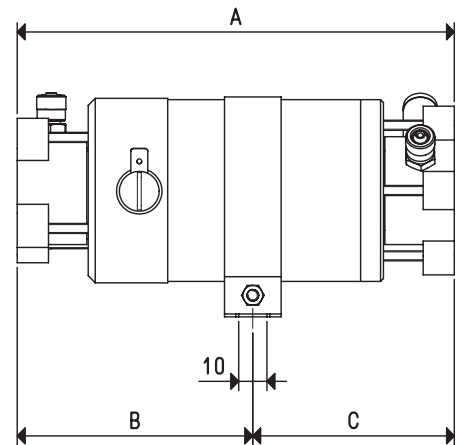
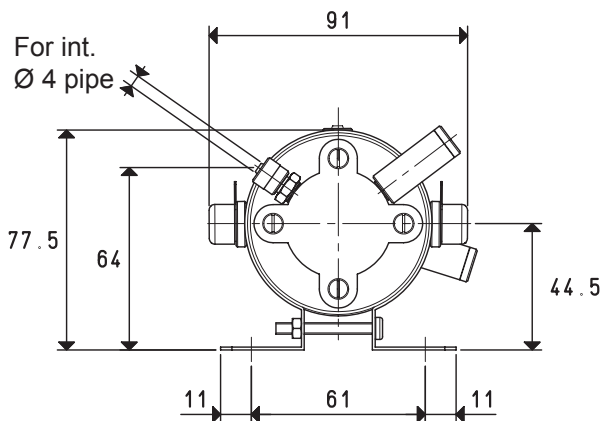

Art.		H25 R CC	H45 R CC	H45 DR CC
Nominal capacity:				
Connection in series	l / 1'	11.5	14.5	13.5
Connection in parallel	l / 1'	=	=	13 + 13
Final pressure:				
Connection in series	mbar abs.	200	200	60
Connection in parallel	mbar abs.	=	=	200
Max. pressure	bar (g)	2	2	2
Motor execution	Volt	24 CC	24 CC	24 CC
Motor power	Watt	20	24	30
Electric absorption A		1.6	1.8	
Rotation speed	rev/min ⁻¹	3000	3000	3000
Noise level	dB(A)	≤ 60	≤ 60	≤ 60
Max. weight	Kg	0.96	1.29	1.44
A		130	148	154
B		57	77	83
C		73	71	71
Accessories and spare parts				
Vanes	art.	n° 10 00 H25R 03	n° 10 00 H45R 02	n° 20 00 H25R 03
Silencer filtre	art.	FB 1	FB 1	FB 1
Fittings	art.	RMM5	RMM5	RMM5

3D drawings available at www.vuototecnica.net